

# COUPLINGS

## CONTENTS



## COUPLINGS

ETP BUSHINGS

ELECTROMAGNETIC  
CLUTCHES & BRAKESSPEED CHANGERS  
& REDUCERS

INVERTERS

LINEAR SHAFT DRIVES

TORQUE LIMITERS

ROSTA

## » 020 COUPLINGS

022 Coupling Models

024 Selection Guide

025 Select by Product Characteristics

025 Select by Drive

026 Applications

## » 028 SERVOFLEX

030 Product Lineup

034 SFC

046 SFS

060 SFF

072 SFM

080 SFH

088 Torque Wrenches

## » 090 SERVORIGID

091 SRG

## » 094 HELI-CAL

096 1441/HELI-CAL MINI

097 3002/3005

098 ARM/ACRM

099 DSR/DSCR

## » 102 BAUMANNFLEX

104 ZG

105 LM

106 MM

107 MF

## » 110 PARAFLEX

111 CPE

112 CPU

## » 114 SCHMIDT

115 NSS

120 DL

## » 122 STEPFLX

124 STF

## » 128 MIKI PULLEY STARFLEX

132 ALS R

134 ALS Y

136 ALS B

## » 144 SPRFLEX

145 AL

## » 148 BELLOWFLEX

149 CHP

## » 150 CENTAFLEX

152 Product Lineup

158 CF-A

170 CF-H

174 CF-X

180 CF-B





184 CM

## » 612 MIKI PULLEY Hole-Drilling Standards

Coupling Models

SERIES	SERVOFLEX		
MODELS	SFC SA2	SFS S	SFF SS
		 >> P.046	 
		SFS W	
	SFC DA2	 >> P.048	SFF DS
		SFS G	 
		 >> P.050	  >> P.064

SERIES	HELI-CAL		
MODELS	1441 / HELI-CAL MINI	ARM	DSR
			
			>> P.099
	3000	ACRM	DSCR
			
		>> P.097	>> P.099

SERIES	STEPFLEX	MIKI PULLEY STARFLEX		SPRFLEX
MODELS	STF	ALS R	ALS B	AL
				
		>> P.124	>> P.132	>> P.145
		ALS Y		
				

## COUPLINGS

ETP BUSHINGS

ELECTROMAGNETIC  
CLUTCHES & BRAKES

SPEED CHANGERS  
& REDUCERS

INVERTERS

LINEAR SHAFT DRIVES

TORQUE LIMITERS

ROSTA

### SERIES

Metal Couplings	Metal Disc Couplings <b>SERVOFLEX</b>
	High-rigidity Couplings <b>SERVORIGID</b>
	Metal Slit Couplings <b>HELI-CAL</b>
	Metal Coil Spring Couplings <b>BAUMANNFLEX</b>
Rubber and Plastic Couplings	Pin Bushing Couplings <b>PARAFLEX</b>
	Link Couplings <b>SCHMIDT</b>
	Dual Rubber Couplings <b>STEPFLEX</b>
	Jaw Couplings <b>MIKI PULLEY STARFLEX</b>
	Jaw Couplings <b>SPRFLEX</b>
	Plastic Bellows Couplings <b>BELLOWFLEX</b>
	Rubber and Plastic Couplings <b>CENTAFLEX</b>

### SERVORIGID

SFM SS



>> P.072

SFH S



>> P.080

SRG



>> P.091

SFM SS



>> P.074

SFH G



>> P.082

### BAUMANNFLEX

ZG



>> P.104

MM



>> P.106

### PARAFLEX

CPE



>> P.111

### SCHMIDT

NSS



>> P.115

LM



>> P.105

MF



>> P.107

CPU



>> P.112

DL



>> P.120

### BELLOWFLEX

CHP



>> P.149

### CENTAFLEX

CF-A



>> P.158

CF-X



>> P.174

CM



>> P.184

CF-H



>> P.170

CF-B



>> P.180

Selection Guide

1 Select a type

Refer to the list of parts (p. 022), Select by Product Characteristics (p. 025), Select by Driver (p. 025), and Applications (p. 026) sections in order to select the best coupling for the application at hand.

2 Select a size

Select a size with a nominal torque (for SERVOFLEX, a rated torque) higher than the load torque. Make sure to also consider load conditions when making a selection.

3 Check the max. bore diameter

When selecting a model, make sure to check that the mounting shaft diameter is smaller than the maximum bore diameter of the coupling.

4 Overview

Once the model has been selected, check the rated torque, maximum rotation speed, dimensions, and other specifications again to confirm that they satisfy the usage conditions.

Quick Search



You can use the website quick search feature to narrow down your search for couplings.



COUPLINGS

ETP BUSHINGS

ELECTROMAGNETIC CLUTCHES & BRAKES  
SPEED CHANGERS & REDUCERS

INVERTERS

LINEAR SHAFT DRIVES

TORQUE LIMITERS

ROSTA

SERIES

Metal Couplings	Metal Disc Couplings <b>SERVOFLEX</b>
	High-rigidity Couplings <b>SERVORIGID</b>
	Metal Slit Couplings <b>HELI-CAL</b>
	Metal Coil Spring Couplings <b>BAUMANNFLEX</b>
Rubber and Plastic Couplings	Pin Bushing Couplings <b>PARAFLEX</b>
	Link Couplings <b>SCHMIDT</b>
	Dual Rubber Couplings <b>STEPFLEX</b>
	Jaw Couplings <b>MIKI PULLEY STARFLEX</b>
Jaw Couplings <b>SPRFLEX</b>	
Plastic Bellows Couplings <b>BELLOWFLEX</b>	
Rubber and Plastic Couplings <b>CENTAFLEX</b>	

Select by Product Characteristics

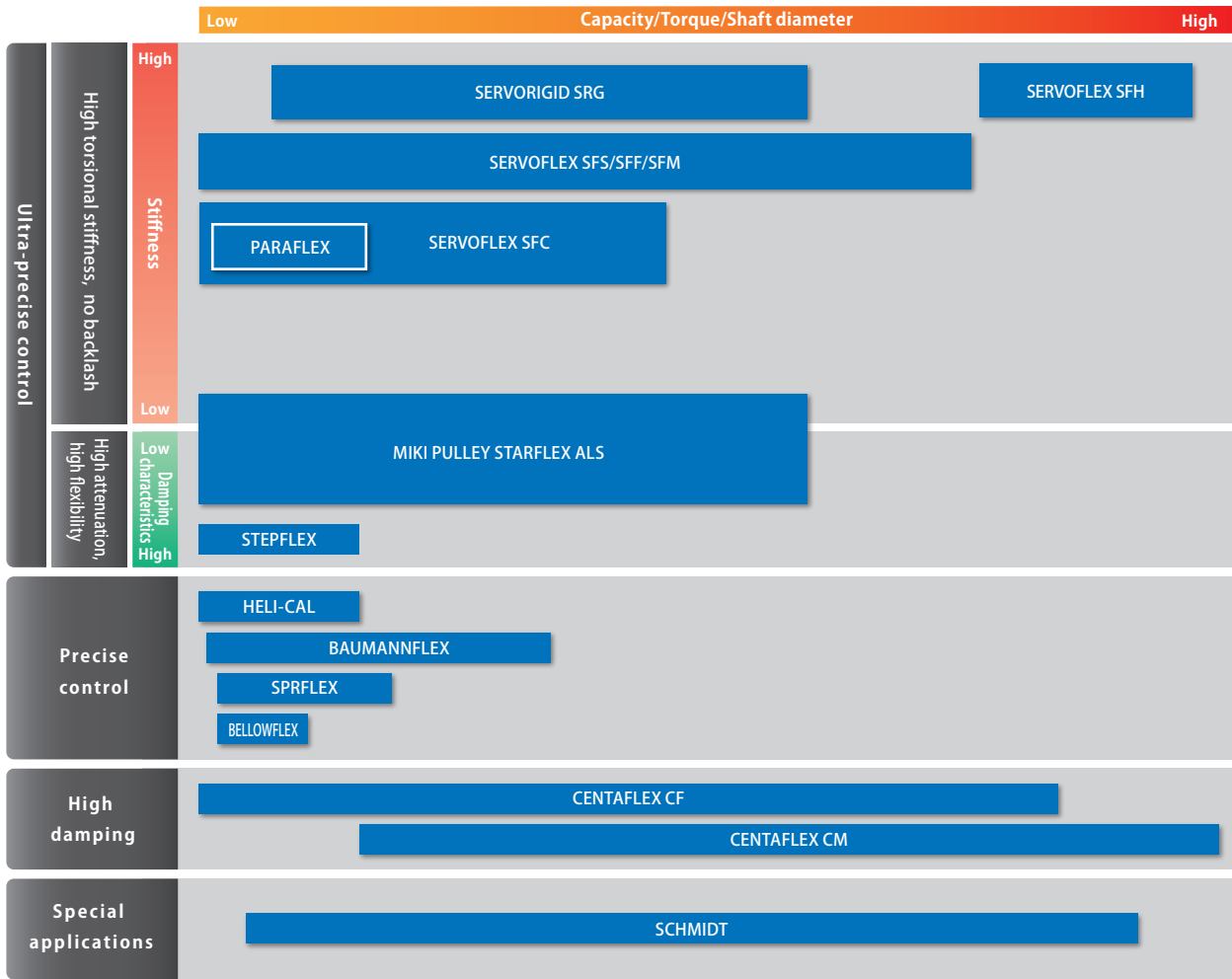

Select by Drive

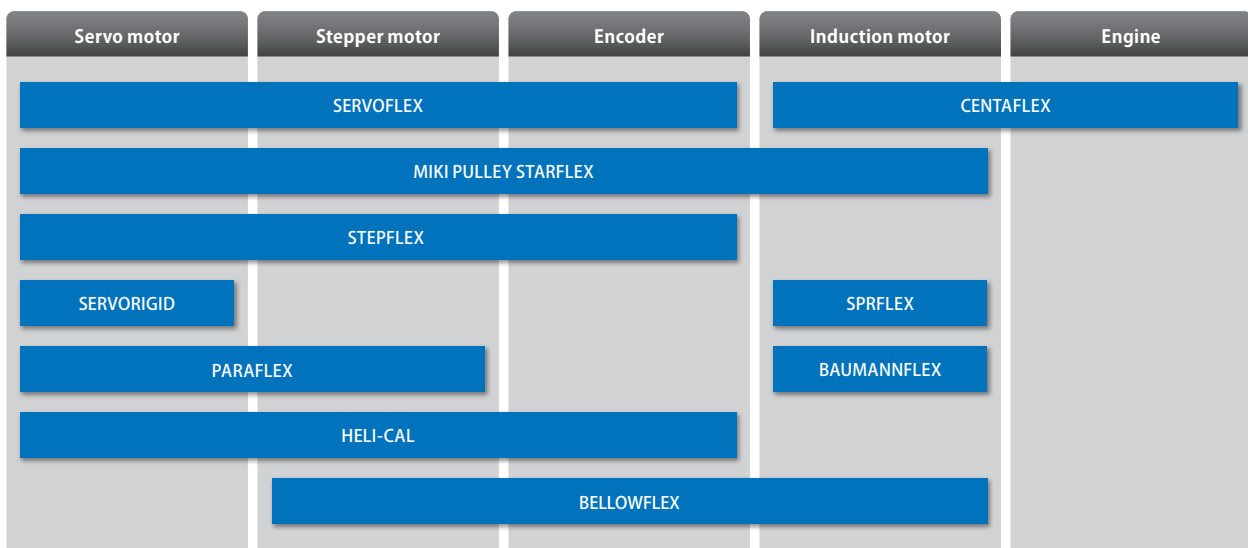

Applications

**Product model** ALS R  
**Employed device** Vacuum Pump

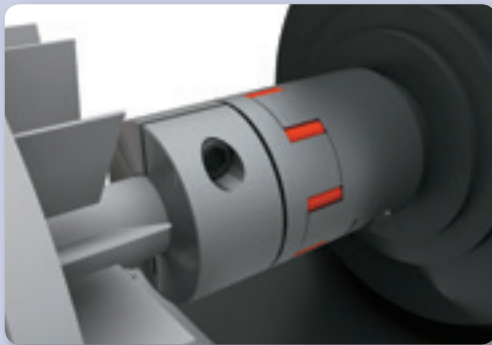
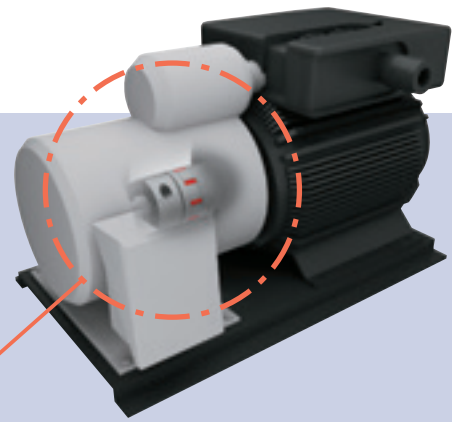

MIKI PULLEY STARFLEX coupling for connecting the drive unit.  
 Simple structure and easy maintenance.

**Product model** CF-A OZ  
**Employed device** Pleasure Boat

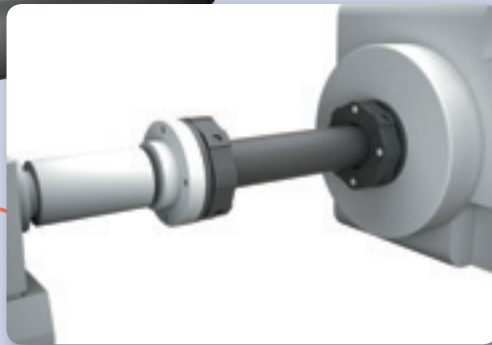
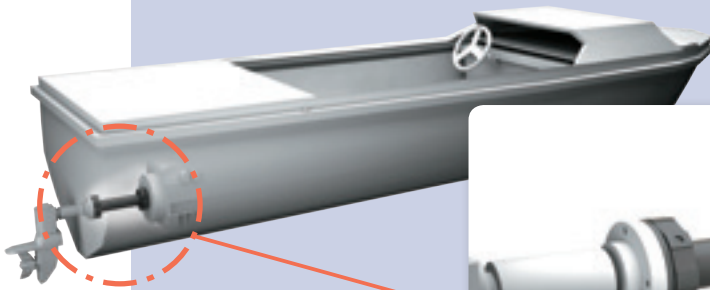

CENTAFLEX coupling and floating shaft (for high-speed rotation) are used to connect the engine and the propeller.

**Product model** SFC  
**Employed device** Dicing Saw

SERVOFLEX for connecting the servo motor and ball screw. It is used for ultra-precision machining of semiconductor wafers.

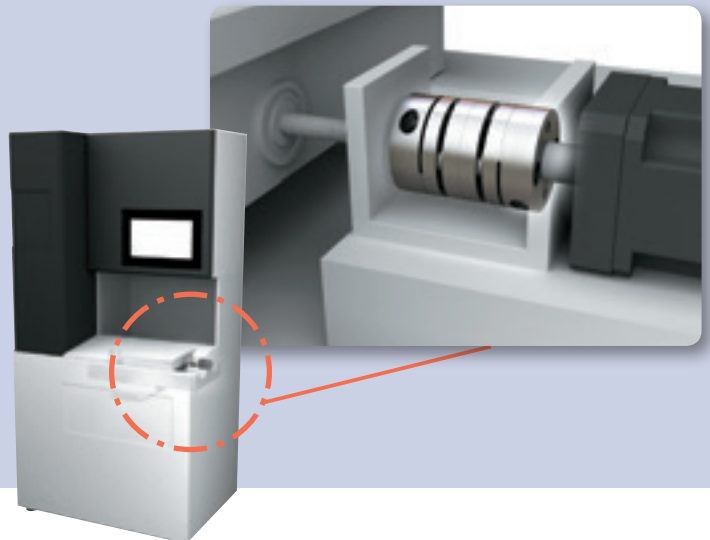

COUPLINGS

ETP BUSHINGS

ELECTROMAGNETIC CLUTCHES & BRAKES

SPEED CHANGERS & REDUCERS

INVERTERS

LINEAR SHAFT DRIVES

TORQUE LIMITERS

ROSTA

SERIES

Metal Couplings	Metal Disc Couplings <b>SERVOFLEX</b>
	High-rigidity Couplings <b>SERVORIGID</b>
	Metal Slit Couplings <b>HELI-CAL</b>
	Metal Coil Spring Couplings <b>BAUMANNFLEX</b>
	Pin Bushing Couplings <b>PARAFLEX</b>
Rubber and Plastic Couplings	Link Couplings <b>SCHMIDT</b>
	Dual Rubber Couplings <b>STEPFLEX</b>
	Jaw Couplings <b>MIKI PULLEY STARFLEX</b>
	Jaw Couplings <b>SPRFLEX</b>
	Plastic Bellows Couplings <b>BELLOWFLEX</b>
	Rubber and Plastic Couplings <b>CENTAFLEX</b>

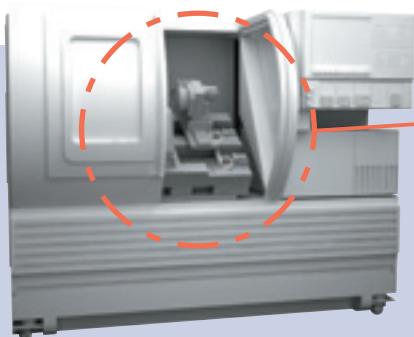

**Product model** SFF  
**Employed device** CNC Lathe

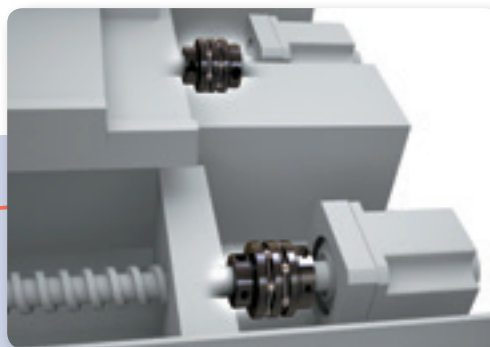

Ultra-high stiffness coupling SFF model for connecting the servo motor and feed shaft. The rated torque is higher than the conventional models, and the coupling size and the moment of inertia can be reduced.

SERVOFLEX coupling for the head of a chip mounter.

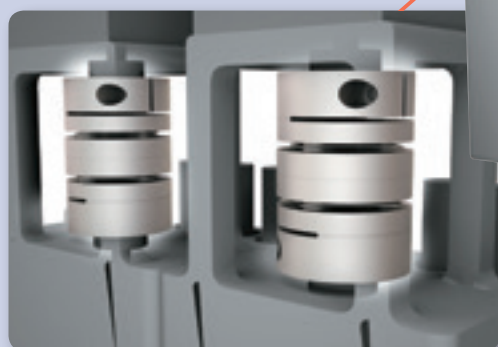

**Product model** SFC  
**Employed device** Chip Mounter

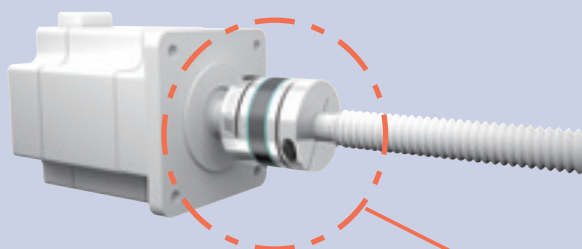

**Product model** STF  
**Employed device** General-purpose Feed Shaft

The high damping performance STEPFLEX coupling is used to connect the stepper motor and the ball screw.

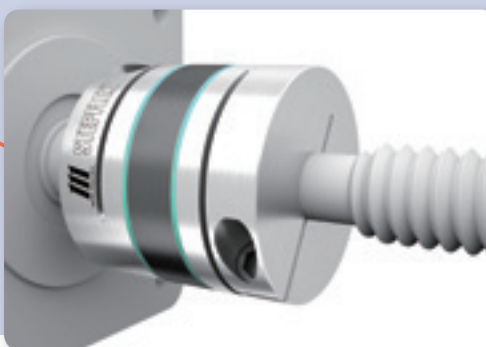

# Plastic Bellows Couplings

## BELLOWFLEX

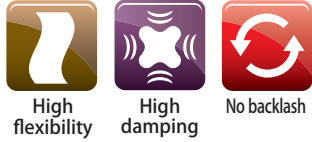

Max. nominal torque [N·m]	1.5
Bore ranges [mm]	φ 3 ~ 12
Operating temperature [°C]	-20 ~ 60
Driver	Induction motor, stepper motor, encoder
Application	Automated teller machines, inspection equipment, printing machinery

### Plastic Bellows Coupling Ideal for Stepper Motors and Encoders



Bellows couplings that use a plastic (polyester resin) boot with plenty of elasticity in order to achieve high damping performance and extremely small counterforce from mounting misalignment. A compact design that unitizes an aluminum alloy hub and plastic boot means there is no backlash.



#### Main Features

Allows Angular Deflection up to 10°



Extremely Small Counterforce due to Misalignment

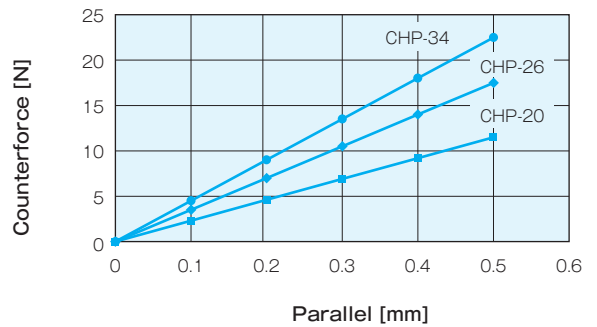

#### Structure and Materials

Hub material: Aluminum alloy

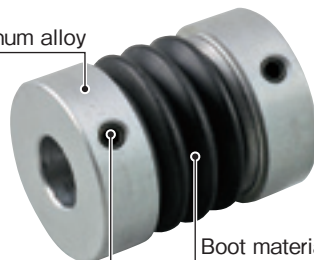

Boot material: Polyester resin

Hexagon head set screw material:  
Alloy steel for machine structural use  
Surface finishing: Black coating

# CHP Models

COUPLINGS

ETP BUSHINGS

ELECTROMAGNETIC CLUTCHES & BRAKES

SPEED CHANGERS & REDUCERS

INVERTERS

LINEAR SHAFT DRIVES

TORQUE LIMITERS

ROSTA

SERIES

Metal Disc Couplings	SERVOFLEX
	High-rigidity Couplings
	SERVORIGID
	Metal Slit Couplings
Metal Couplings	HELI-CAL
	Metal Coil Spring Couplings
	BAUMANNFLEX
Pin Bushing Couplings	PARAFLEX
	Link Couplings
Rubber and Plastic Couplings	SCHMIDT
	Dual Rubber Couplings
	STEPFLEX
	Jaw Couplings
	MIKI PULLEY STARFLEX
	Jaw Couplings
	SPRFLEX
	Plastic Bellows Couplings
	BELLOWFLEX
	Rubber and Plastic Couplings
CENTAFLEX	

MODELS

CHP

## Specifications

Model	Torque		Misalignment			Max. rotation speed [min <sup>-1</sup> ]	Static torsional stiffness [N-m/rad]	Moment of inertia [kg-m <sup>2</sup> ]	Mass [kg]
	Nominal [N-m]	Max. [N-m]	Parallel [mm]	Angular [°]	Axial [mm]				
CHP-20	0.4	0.8	0.5	10	± 0.5	9000	5.9	6.30 × 10 <sup>-7</sup>	0.012
CHP-26	0.7	1.4	0.5	10	± 0.5	7000	12.5	2.40 × 10 <sup>-6</sup>	0.026
CHP-34	1.5	3.0	0.5	10	± 0.5	5500	32.8	7.90 × 10 <sup>-6</sup>	0.051

\* Static torsional stiffness values given are from measurements taken at 20°C  
 \* The moment of inertia and mass are measured for the minimum bore diameter.

## Dimensions

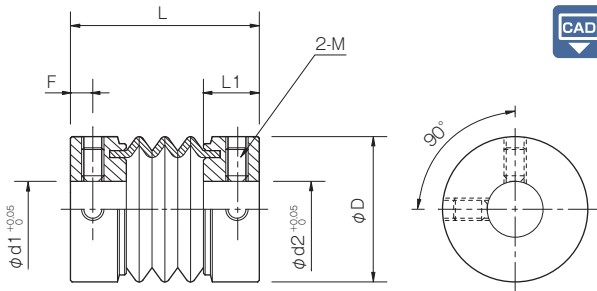

Model	d1 · d2		D	L	L1	F	M
	Min.	Max.					
CHP-20	3	8	20	28	8	3	M3
CHP-26	6	13	26	34	10	4	M4
CHP-34	8	18	34	40	12	5	M5

\* For combination with a CHP-20 that has a bore diameter of ø3, open the set screw to an angle of 120°.

Model	Standard bore diameter d1-d2 [mm]					
	3-3	5-5	6-6	8-8	10-10	12-12
CHP-20	●	●	●	●	●	●
CHP-26			●	●	●	●
CHP-34				●	●	●

\* The recommended processing tolerance for paired mounting shafts is the h8 class.  
 \* Non-standard bore diameters require additional processing.

### How to Place an Order



## Items Checked for Design Purposes

### Special Items to Take Note of

- You should note the following to prevent any problems.
- (1) Always be careful of parallel, angular, and axial misalignment.
  - (2) Always tighten bolts with the specified torque.

### Precautions for Handling

- (1) Couplings are designed for use within an operating temperature range of -20°C to 60°C. Although BELLOWFLEX couplings are designed to be waterproof and oilproof, do not subject them to excessive amounts of water or oil as these may cause deterioration. Use and storage in direct sunlight may shorten coupling service life, so cover couplings appropriately.
- (2) Be careful, when working on the bore, to not change the shape of the hub or get cutting residue inside the boot.
- (3) To get full coupling performance, mount couplings so that differences between coupling centers during operation are within the misalignment shown in the specifications table. However, this misalignment is the maximum value when each occurs independently, so make the allowable value when they combine 50% or less of this value.

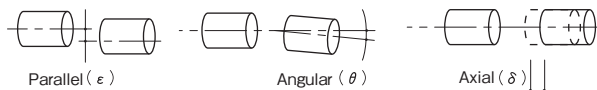

- (4) Remove any rust, dust, oil or the like from the inner diameter surfaces of the shaft and coupling.
- (5) Be careful not to place more bending, tensile, or compressive load on the coupling than necessary when inserting a shaft into a coupling. Also, the length of insertion of the shaft into the coupling should be the dimension L1 on the dimensions table.
- (6) Tighten set screws with hex socket heads to the tightening torques shown below using a calibrated torque screwdriver.

Size of hex-socket-head set screw	M3	M4	M5
Tightening torque [N-m]	0.7	1.7	3.6

## Selection Procedures

- (1) Find the torque, Ta, applied to the coupling using the output capacity, P, of the driver and the usage rotation speed, n.

$$T_a \text{ [N-m]} = 9550 \times \frac{P \text{ [kW]}}{n \text{ [min}^{-1}\text{]}}$$

- (2) Determine the service factor K from the usage and operating conditions, and find the corrected torque, Td, applied to the coupling.

$$T_d \text{ [N-m]} = T_a \times K_1 \times K_2$$

### Service factor based on load property: K1

Load properties	Constant	Vibrations: Small	Vibrations: Medium	Vibrations: Large
	K1	1.0	1.25	1.75

### Service factor based on operating temperature: K2

Temperature [°C]	- 20	0	+ 20	+ 40	+ 60
K2		1.0		1.2	1.3

- (3) Set the size so that the nominal torque of the coupling Tn is at least equal to the corrected torque Td.

$$T_n \geq T_d$$

- (4) Select a size that results in a maximum torque, Tm, for the coupling that is at least equal to the peak torque, Ts, generated by the driver, follower or both. Maximum torque refers to the maximum amount of torque that can be applied for a set amount of time considering eight hours of operation per day and up to around ten instances.

$$T_m \geq T_s$$

- (5) When the required shaft diameter exceeds the maximum bore diameter of the selected size, select a suitable coupling.